

GFC-503 (120178) 20 OZ. Delrin Gravity Feed Cup

Important: Before using this equipment, read all safety precautions and instructions. Keep for future use.

DESCRIPTION

GFC-503 (120178) 20 Oz. Cup

The cup is constructed from durable delrin to provide trouble-free operation. The disposable cup lid is recyclable and is constructed with recycled polyethylene. The lid has a unique drip check to prevent paint from dripping out of the vent in the lid.

ASSEMBLY OF CUP TO GUN

1. Remove one of the cup/gun washers (4) from the poly bag.
2. Place this washer in the fluid inlet of the gun body. See Cup Drawing at right.
3. Store remaining washer in safe place for future use.
4. Place filter (3) in cup outlet at this time if desired. See Cup Drawing at right.
5. Assemble cup to gun and tighten hand tight.

FILLING WITH PAINT

Fill the cup to within 3/4" (18mm) from the top of the cup. **Do not overfill.**

INSTALLING THE LID

Place plastic lid on the top of the cup, and **push in the center of the lid to assemble lid.** Fold vent cap and push onto center portion of lid (if vent cap is not already assembled).

CLEANING

Note

For routine cleaning, it is not necessary to remove cup from gun. Do not remove washer (4) from gun. If washer (4) is removed, it must be replaced.

CAUTION

Do not soak the lid in solvent for extended periods of time. Doing so could cause cup/lid sealing problems and leakage.

The cup lid is designed to be disposable but may be cleaned and reused if slightly contaminated with overspray. **If lid becomes tight, or does not fit, it is due to extended soaking in solvent. Let lid air dry overnight and the lid should return to its original size and fit.**

Remove lid and properly dispose of any excess paint. Pour in a small amount of clean solvent. The amount will vary with different coatings and solvents. Reinstall lid. Shake cup to wash down the inside surfaces. **Hold lid while shaking to prevent lid from coming off.** Pull trigger to allow some solvent to be flushed through gun. Remove lid and pour out dirty solvent. Add a small amount of clean solvent and repeat procedure. Wipe exterior of lid with a clean cloth and clean solvent.

If a paint filter was used in the bottom of the cup outlet, it should be removed and cleaned or replaced at this time. Dispose of used cup lid if contaminated and replace with new.

View Showing Filter/Cup Installation

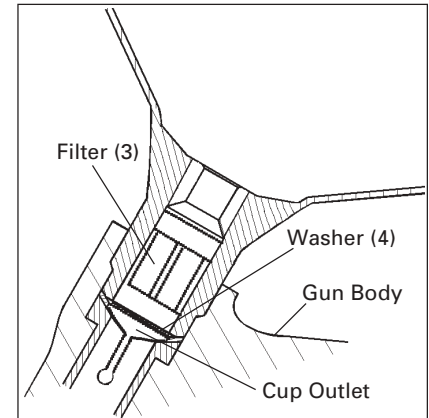

GFC-503 Cup

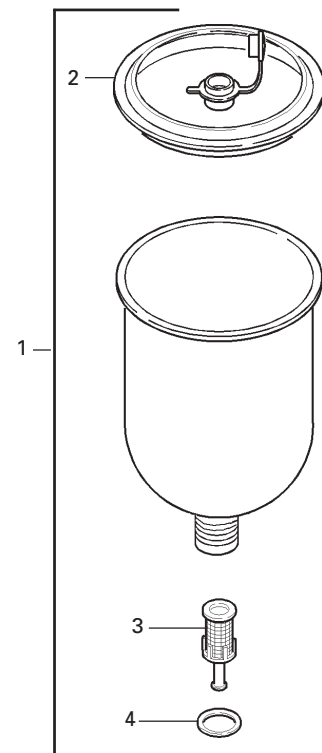

PARTS LIST

Ref. No.	Order No.	Model No.	Description
1	120178	GFC-503	20 Oz. Delrin Gravity Feed Cup
2	190944	GFC-404-K2	Disposable Lid Kit (Kit of 2)
3	190181	KGP-5-K5	Filter Kit (Kit of 5)
4	192151	KGP-13-K5	Gasket (Kit of 5)

WARRANTY

This product is covered by DeVilbiss' 1 Year Limited Warranty.
See SB-1-000 which is available upon request.

DeVILBISS WORLDWIDE SALES AND SERVICE LISTING – www.devilbiss.com

INDUSTRIAL FINISHING

DeVilbiss has authorized distributors throughout the world. **FOR TECHNICAL ASSISTANCE OR THE DISTRIBUTOR NEAREST YOU, CALL TOLL FREE 1-888-992-4657 (U.S.A. AND CANADA ONLY). FOR LOCAL CALLS, SEE LISTING BELOW.**

U.S./Canada Sales & Customer Service Office GLENDALE HEIGHTS, IL 60139	Address 195 Internationale Blvd.	Telephone No. (630) 237-5000 Toll Free Fax No. 1-877-790-6965
---	-------------------------------------	---

AUTOMOTIVE REFINISHING

DeVilbiss has authorized distributors throughout the world. For equipment, parts and service, check the Yellow Pages under "Automobile Body Shop Equipment and Supplies". **FOR TECHNICAL ASSISTANCE, CALL TOLL FREE 1-800-445-3988 (U.S.A. ONLY). FOR LOCAL CALLS, SEE LISTING BELOW.**

U.S. Customer Service Office MAUMEE, OH 43537	Address 1724 Indian Wood Circle	Telephone No. (419) 891-8100 Toll Free Fax No. 1-800-445-6643
--	------------------------------------	---

DEVILBISS